

# Vanguard™ 18.0

## Gross HP

## 570 CC

Bore 2.83 in. (72 mm)

Stroke 2.75 in. (70 mm)



FEATURING  
COOLER/CLEANER  
TECHNOLOGY



### Features:

- Dura-Bore™ cast iron cylinder sleeve for extended life
- Dependable float feed type carburetor with integral fuel pump for remote mount fuel tank
- Maintenance-free Magnetron® electronic ignition for quick, dependable starts
- Dual-Clean™ air cleaner pleated paper filter with a foam pre-cleaner ensures maximum protection for extended engine life
- Full pressure lubrication with spin-on oil filter assures controlled lubrication for extended component life
- Overhead valve design (OHV) for cooler operation and longer valve life
- Buyer protection package provides two-year commercial engine warranty

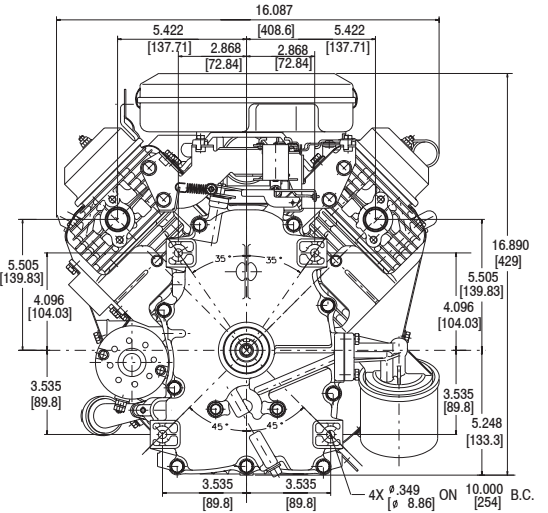
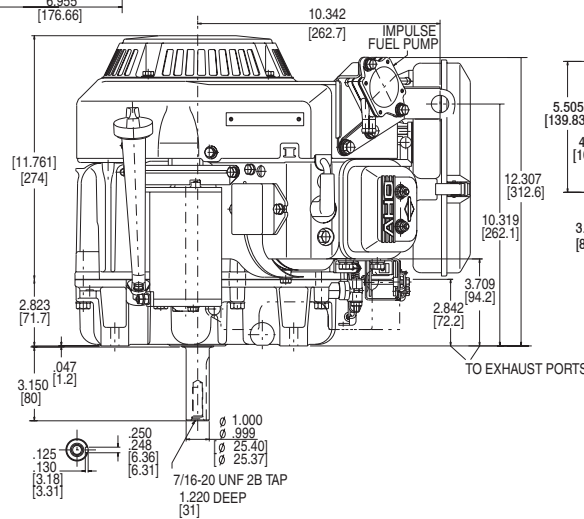
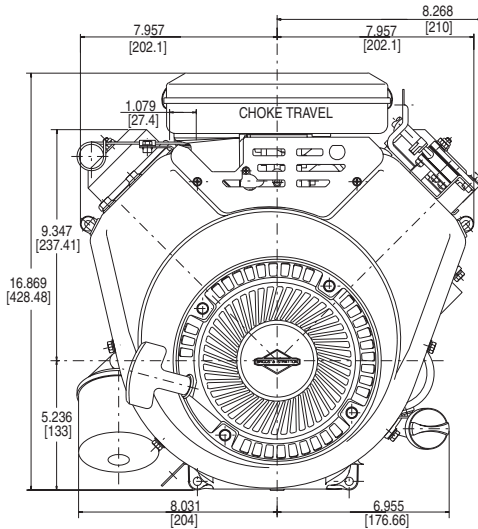

Model Type	Shipping Weight	Crankshaft	Crankshaft (P.T.O.) Extension	Dimension	Starter Position Bolt-On/Changeable	Governor	Controls	Exhaust System	Fuel Tank (Quarts)	Ground Wire Terminal	Ext. Oil Fill & Dipstick	Oil Pump w/Filter	Remote Choke	Top Governor Speed	Notes
356776															
0046	81	809807	Tapped 7/16-20, Keyway, 1" dia.	3-5/32(b)	9	M	R	•	■	X	X	X	X	3600	▼
356777															
0034	86	809807	Tapped 7/16-20, Keyway, 1" dia.	3-5/32(b)		M	R	•	■	X	X	X	X	3300	†

• Exhaust manifold and muffler omitted. See Engine Accessories Catalog MS-3880 for Exhaust Manifold and Muffler Options.

■ Fuel tank omitted † Engine equipped with 12 Volt Gear Drive Starter and 16 Amp DC Alternator. ▼ Engine equipped with 9 Amp DC Alternator.